

System No. CW-D-2035

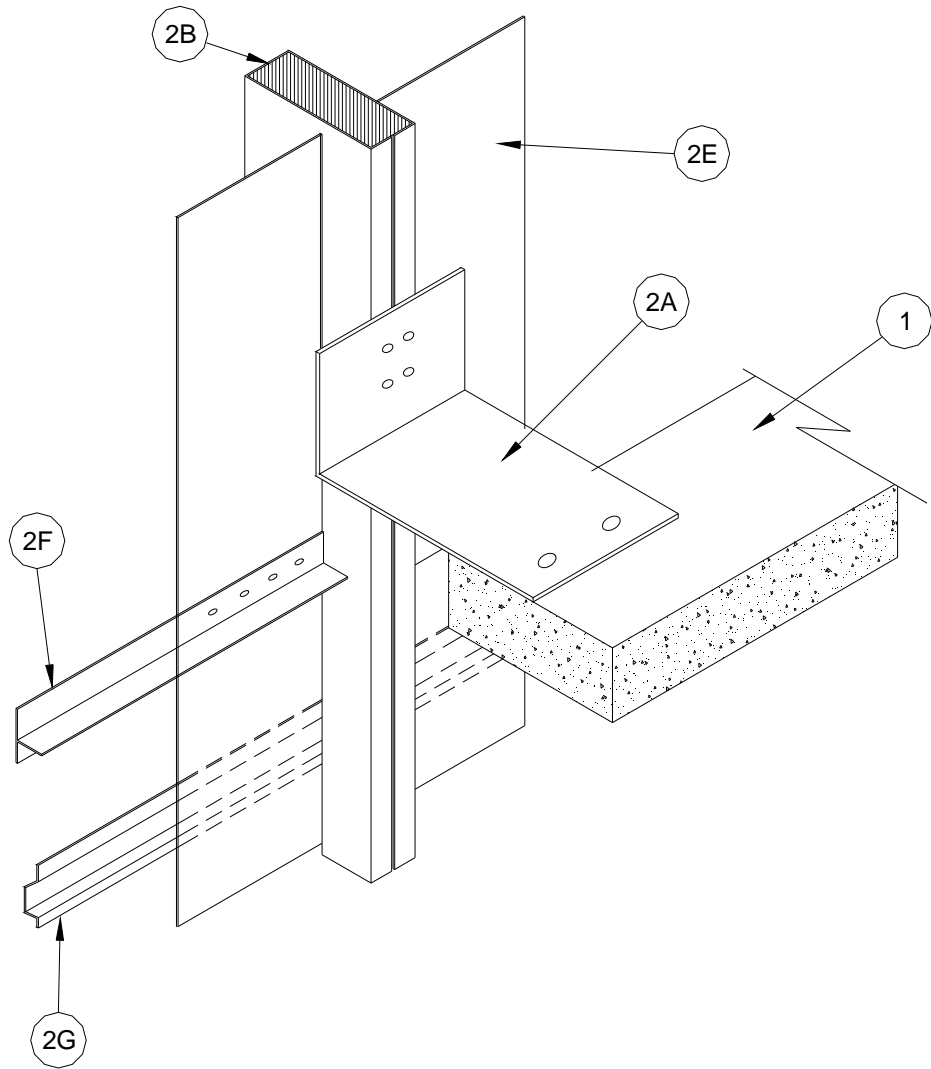

System No. CW-D-2035

1. **Floor Assembly** - Min 4-1/2 in. thick reinforced lightweight or normal weight (100-150 pcf) structural concrete.
2. **Curtain Wall Assembly** - The curtain wall assembly shall incorporate the following construction features:
 - A. **Mullion Mounting Angles** - Min 4 in. wide by 1/4 in. thick steel angles with one nom 4 in. leg for attachment to mullion and with one leg approx 4 in. longer than width of linear opening between floor assembly and wall assembly. Angles attached to top of floor with two min 3/8 in. diam by 1-1/4 in. long steel masonry anchors.
 - B. **Mullions** - The rectangular tubing mullions shall consist of two inter-locking halves with overall assembled size of min 2-1/2 in. wide by 5-3/4 in. deep and shall be formed from min 0.110 in. thick aluminum. Mullion halves to be tightly packed and filled with nom 8 pcf mineral wool insulation between transoms used to frame top and bottom edges of spandrel panels (Item 2K) prior to assembling the halves together. Mullions spaced max 60 in. OC and secured to mullion mounting angles at each floor level with four min No. 12 by 1 in. long steel self-drilling, self-tapping screws (two screws in each mullion half). Interior face of mullions to be max 8 in. from edge of floor assembly.
 - C. **Transoms** - The rectangular tubing transoms shall be min 2-1/2 in. wide by 5-3/4 in. deep and shall be formed from min 0.100 in. thick aluminum. Transoms used to frame top and bottom edges of spandrel panels (Item 2K) to be spaced min 72 in. OC. Transom forming sill of vision panel (Item 2D) to be located such that its bottom surface is at height of 33 in. above the top surface of the floor (Item 1).
 - D. **Vision Panels** - Nom 1 in. thick (double pane) transparent heat-strengthened glass panels. Each panel secured in position with aluminum pressure plates in conjunction with glazing gaskets and steel screws.
 - E. **Back Pan** - No. 22 gauge galvanized steel panels installed between mullions and transoms used to frame spandrel panels (Item 2K). Back pan provided with min 1/2 in. wide lip around all four sides. Back pan recessed 2 in. from interior face of framing and screw-attached to mullions and transom along all sides with min No. 8 by 1/2 in. long self-drilling, self-tapping steel screws spaced max 8 in. OC.
 - E1. **Fill, Void or Cavity Material* - Sealant (not shown)** - Min 1/4 in. bead of sealant applied along entire perimeter of back pan on interior side.
NUCO INC. - Self Seal GG-200
 - F. **Stiffener T** - Nom 1-1/2 by 1-1/2 by 1-1/2 in. T-shaped stiffener formed of 22 gauge galv steel. Secured to interior side of back pan with min No. 10 by 1/2 in. long self-drilling, self-tapping steel screws spaced max 4 in. OC. on both upper and lower portion of T. Stiffener T located at horizontal seam of curtain wall insulation (Item 2H).

- G. **Stiffener Channels** - Nom 2 in. wide by 1-1/2 in. deep hat-shaped channels formed of 22 gauge galv steel. Secured to exterior side of back pan with min No. 10 by 1/2 in. long self-drilling, self-tapping steel screws spaced max 4 in. OC. on both upper and lower portion of channel. A min of three channels used within each spandrel panel. One channel to be located with its centerline approx 10 in. below floor and one channel to be located with its centerline approx 6 in. above floor. A third channel is to be located approx 12 in. above the bottom transom.
- H. **Curtain Wall Insulation*** (Interior) - Min 2 in. thick mineral wool board insulation, unfaced or faced on one side with aluminum foil/scrim vapor retarder, supplied in min 36 in. wide boards. Insulation boards to be installed on interior side of back pan with no vertical seams and with horizontal seams tightly butted and spaced min 33 in. OC. A full-width board shall be installed at the bottom of the spandrel panel and tightly-fitted between vertical mullions, flush with interior surface of framing. The remainder of the spandrel panel framing above the full-width board shall be filled in with an additional length of board cut to fit tightly between mullions and with the horizontal seams between board sections tightly butted. The boards shall be secured to the back pan with No. 12 gauge galv steel cup head weld pins. Weld pins to be located a max of 8 in. OC along all edges of each board. Additional rows of weld pins shall be located within each board a max of 12 in. OC. When faced boards are used, butted seams to be covered with min 4 in. wide aluminum foil tape.

ROXUL INC — RHT-80

- I. **Curtain Wall Insulation*** (Exterior) - Min 3 in. thick mineral wool board insulation, unfaced or faced on one side with aluminum foil/scrim vapor retarder, supplied in min 36 in. wide boards. Insulation boards to be installed on exterior side of back pan with no vertical seams and with horizontal seams tightly butted and spaced min 33 in. OC. A full-width board shall be installed at the bottom of the spandrel panel and tightly-fitted between vertical mullions, flush with interior surface of framing. The remainder of the spandrel panel framing above the full-width board shall be filled in with an additional length of board cut to fit tightly between mullions and with the horizontal seams between board sections tightly butted. The boards shall be grooved to tightly fit around stiffener channels (Item 2 G). The boards shall be secured to the back pan with No. 12 gauge galv steel cup head weld pins. Weld pins to be located a max of 8 in. OC along all edges of each board. Additional rows of weld pins shall be located within each board a max of 12 in. OC. When faced boards are used, butted seams to be covered with min 4 in. wide aluminum foil tape.

ROXUL INC — RHT-80

- J. **Framing Covers - Curtain Wall Insulation*** - Min 8 in. wide strips cut from the same min 2 in. thick mineral wool batt insulation used for the curtain wall insulation (Item 2H). Framing covers to be centered over mullions between transoms used to frame top and bottom edges of spandrel panels (Item 2K) and secured to the back pan with No. 12 gauge galv steel cup head weld pins spaced a max 8 in. OC. When faced boards are used, edges of framing covers to be covered with min 4 in. wide aluminum foil tape.

ROXUL INC — RHT-80

- K. **Spandrel Panels** - Nom 1/4 in. thick opaque heat-strengthened or tempered glass or nom 1/8 in. thick aluminum panels with 1/4 in. thick edges. Each panel secured in position with aluminum pressure plates in conjunction with gaskets and steel screws.
3. **Safing System** - Max separation between edge of floor assembly and face of framing members (at time of installation) is 8 in. The safing system is designed to accommodate vertical shear movement up to a max of 5 percent of its installed width. The safing system shall incorporate the following construction features:
- A. **Forming Material*** - Min 4.0 pcf mineral wool batt insulation installed in linear gap between the curtain wall and the edge of the concrete floor slab as a permanent form. Material to be cut to a 4-1/4 in. width and stacked to a thickness which is at least 25 percent greater than the width of the linear gap. The material is compressed and inserted cut-edge-first into the linear gap and recessed from top surface of floor to accommodate the required thickness of fill material.
- ROXUL INC — SAFE**
FIBREX INSULATIONS INC. – FBX Safing Insulation
ROCK WOOL MANUFACTURING COMPANY - Safing Board
- B. **Fill, Void or Cavity Materials* - Sealant** - Min 1/4 in. thickness of fill material applied within the joint, flush with top surface of floor.
- NUCO INC. - Self Seal SL-100, Self Seal GG-200**

*Bearing the UL Classification Mark